

Current Transducer HAS 50 .. 600-S

For the electronic measurement of currents: DC, AC, pulsed, mixed, with a galvanic isolation between the primary circuit (high power) and the secondary circuit (electronic circuit).



$$I_{PN} = 50 \dots 600 \text{ A}$$

$$V_{OUT} = \pm 4 \text{ V}$$

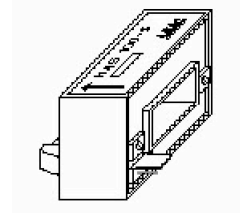

Electrical data

Primary nominal current rms I_{PN} (A)	Primary current, measuring range ⁵⁾ I_{PM} (A)	Type	RoHS since date code
50	± 150	HAS 50-S	45217
100	± 300	HAS 100-S	45325
200	± 600	HAS 200-S	45166
300	± 900	HAS 300-S	45326
400	± 900	HAS 400-S	45333
500	± 900	HAS 500-S	45201
600	± 900	HAS 600-S	45260

V_C	Supply voltage (± 5 %) ⁵⁾	± 15	V
I_C	Current consumption	± 15	mA
\hat{I}_P	Overload capability	30,000	At
V_d	Rms voltage for AC isolation test, 50 Hz, 1 min	3	kV
V_b	Rated isolation voltage rms, safe separation	500 ¹⁾	V
R_{IS}	Isolation resistance @ 500 VDC	> 1000	MΩ
V_{OUT}	Output voltage (Analog) @ ± I_{PN} , $R_L = 10 \text{ k}\Omega$, $T_A = 25^\circ\text{C}$	± 4V ± 40	mV
R_{OUT}	Output internal resistance	approx. 100	Ω
R_L	Load resistance ⁶⁾	> 1	kΩ

Accuracy - Dynamic performance data

X	Accuracy @ I_{PN} , $T_A = 25^\circ\text{C}$ (without offset)	< ± 1	%
ϵ_L	Linearity error ²⁾ (0 .. ± I_{PN})	< ± 1	% of I_{PN}
V_{OE}	Electrical offset voltage, $T_A = 25^\circ\text{C}$	< ± 20	mV
V_{OH}	Hysteresis offset voltage @ $I_P = 0$; after an excursion of $1 \times I_{PN}$	< ± 20	mV
TCV_{OE}	Temperature coefficient of V_{OE}	HAS 50-S HAS 100..600-S	< ± 2 mV/K < ± 1 mV/K
TCV_{OUT}	Temperature coefficient of V_{OUT} (% of reading)	< ± 0.1	%/K
t_T	Response time to 90% of I_P step	< 3	μs
di/dt	di/dt accurately followed	> 50	A/μs
BW	Frequency bandwidth (- 3 dB) ³⁾	DC .. 50	kHz

General data

T_A	Ambient operating temperature	- 10 .. + 80	°C
T_S	Ambient storage temperature	- 25 .. + 80	°C
m	Mass	approx. 60	g
	Standards ⁴⁾	EN 50178: 1997	

- Notes :**
- 1) Pollution class 2, overvoltage category III.
 - 2) Linearity data exclude the electrical offset.
 - 3) Please refer to derating curves in the technical file to avoid excessive core heating at high frequency.
 - 4) Please consult characterisation report for more technical details and application advice.
 - 5) Operating at $\pm 12\text{V} \leq V_C < \pm 15\text{V}$ will reduce the measuring range.
 - 6) If the customer uses $1\text{k}\Omega$ of the load resistor, the primary current has to be limited as the nominal.

Features

- Hall effect measuring principle
- Galvanic isolation between primary and secondary circuit
- Isolation voltage 3000 V~
- Low power consumption
- Extended measuring range ($3 \times I_{PN}$)
- Insulated plastic case made of polycarbonate PBT recognized according to UL 94-V0

Advantages

- Easy mounting
- Small size and space saving
- Only one design for wide current ratings range
- High immunity to external interference.

Applications

- AC variable speed drives
- Static converters for DC motor drives
- Battery supplied applications
- Uninterruptible Power Supplies (UPS)
- Switched Mode Power Supplies (SMPS)
- Power supplies for welding applications.

Application Domain

- Industrial

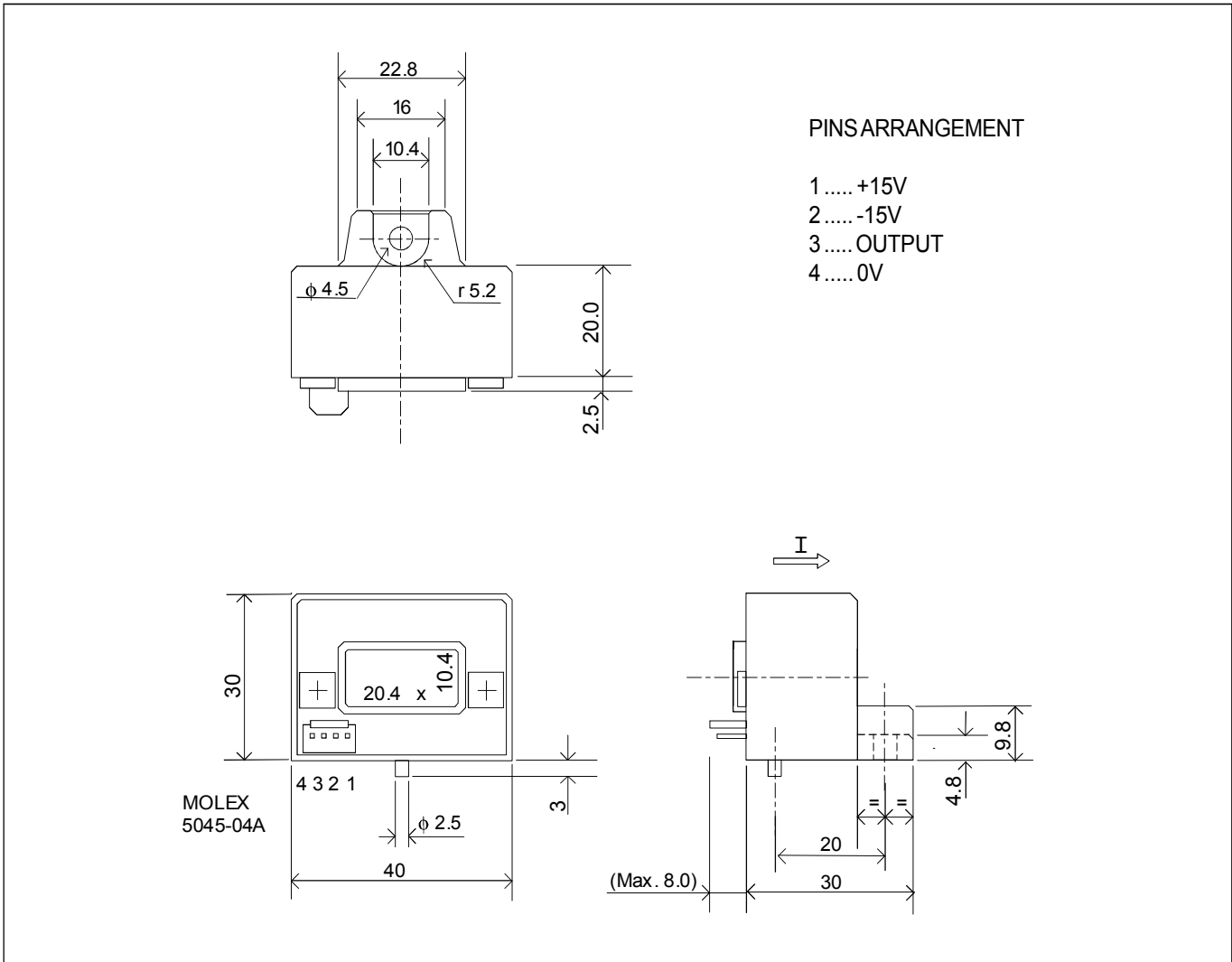
Dimensions HAS 50..600-S (in mm. 1 mm = 0.0394 inch)

Safety

This transducer must be used in electric/electronic equipment with respect to applicable standards and safety requirements in accordance with the following manufacturer's operating instructions.



Caution, risk of electrical shock

When operating the transducer, certain parts of the module can carry hazardous voltage (eg. primary busbar, power supply). Ignoring this warning can lead to injury and/or cause serious damage.

This transducer is a built-in device, whose conducting parts must be inaccessible after installation.

A protective housing or additional shield could be used.

Main supply must be able to be disconnected.