

Current Transducer LA 100-P

$$I_{PN} = 100 \text{ A}$$

For the electronic measurement of currents : DC, AC, pulsed..., with a galvanic isolation between the primary circuit (high power) and the secondary circuit (electronic circuit).

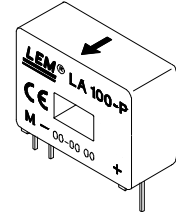

Electrical data

I_{PN}	Primary nominal r.m.s. current	100	A				
I_P	Primary current, measuring range	0 .. ± 150	A				
R_M	Measuring resistance @	$T_A = 70^\circ\text{C}$		$T_A = 85^\circ\text{C}$			
		$R_{M \min}$	$R_{M \max}$	$R_{M \min}$	$R_{M \max}$		
		with $\pm 12 \text{ V}$	@ $\pm 100 \text{ A}_{\max}$	0	50	0	42 Ω
			@ $\pm 120 \text{ A}_{\max}$	0	22	0	14 Ω
		with $\pm 15 \text{ V}$	@ $\pm 100 \text{ A}_{\max}$	0	110	20	102 Ω
	@ $\pm 150 \text{ A}_{\max}$	0	33	20	25 Ω		
I_{SN}	Secondary nominal r.m.s. current	50	mA				
K_N	Conversion ratio	1 : 2000					
V_C	Supply voltage ($\pm 5\%$)	$\pm 12 \dots 15$	V				
I_C	Current consumption	10 (@ $\pm 15 \text{ V}$) + I_S	mA				
V_d	R.m.s. voltage for AC isolation test, 50 Hz, 1 mn	2.5	kV				

Features

- Closed loop (compensated) current transducer using the Hall effect
- Printed circuit board mounting
- Insulated plastic case recognized according to UL 94-V0.

Advantages

- Excellent accuracy
- Very good linearity
- Low temperature drift
- Optimized response time
- Wide frequency bandwidth
- No insertion losses
- High immunity to external interference
- Current overload capability.

Accuracy - Dynamic performance data

X	Accuracy @ I_{PN} , $T_A = 25^\circ\text{C}$	@ $\pm 15 \text{ V} (\pm 5\%)$	± 0.45	%
		@ $\pm 12 \dots 15 \text{ V} (\pm 5\%)$	± 0.70	%
ϵ_L	Linearity		< 0.15	%
I_O	Offset current @ $I_P = 0$, $T_A = 25^\circ\text{C}$	Typ		Max
				± 0.10 mA
I_{OM}	Residual current ¹⁾ @ $I_P = 0$, after an overload of $3 \times I_{PN}$			± 0.15 mA
I_{OT}	Thermal drift of I_O	- $25^\circ\text{C} \dots + 85^\circ\text{C}$	± 0.05	± 0.25 mA
		- $40^\circ\text{C} \dots - 25^\circ\text{C}$	± 0.10	± 0.50 mA
t_{ra}	Reaction time @ 10 % of I_{PN}		< 500	ns
t_r	Response time ²⁾ @ 90 % of I_{PN}		< 1	μs
di/dt	di/dt accurately followed		> 200	A/ μs
f	Frequency bandwidth (-1 dB)		DC .. 200	kHz

Applications

- AC variable speed drives and servo motor drives
- Static converters for DC motor drives
- Battery supplied applications
- Uninterruptible Power Supplies (UPS)
- Switched Mode Power Supplies (SMPS)
- Power supplies for welding applications.

General data

T_A	Ambient operating temperature	- 40 .. + 85	$^\circ\text{C}$
T_S	Ambient storage temperature	- 50 .. + 95	$^\circ\text{C}$
R_S	Secondary coil resistance @	$T_A = 70^\circ\text{C}$	120 Ω
		$T_A = 85^\circ\text{C}$	128 Ω
m	Mass	18	g
	Standards ³⁾	EN 50178 : 1997	

Notes : ¹⁾ The result of the coercive field of the magnetic circuit

²⁾ With a di/dt of 100 A/ μs

³⁾ A list of corresponding tests is available.

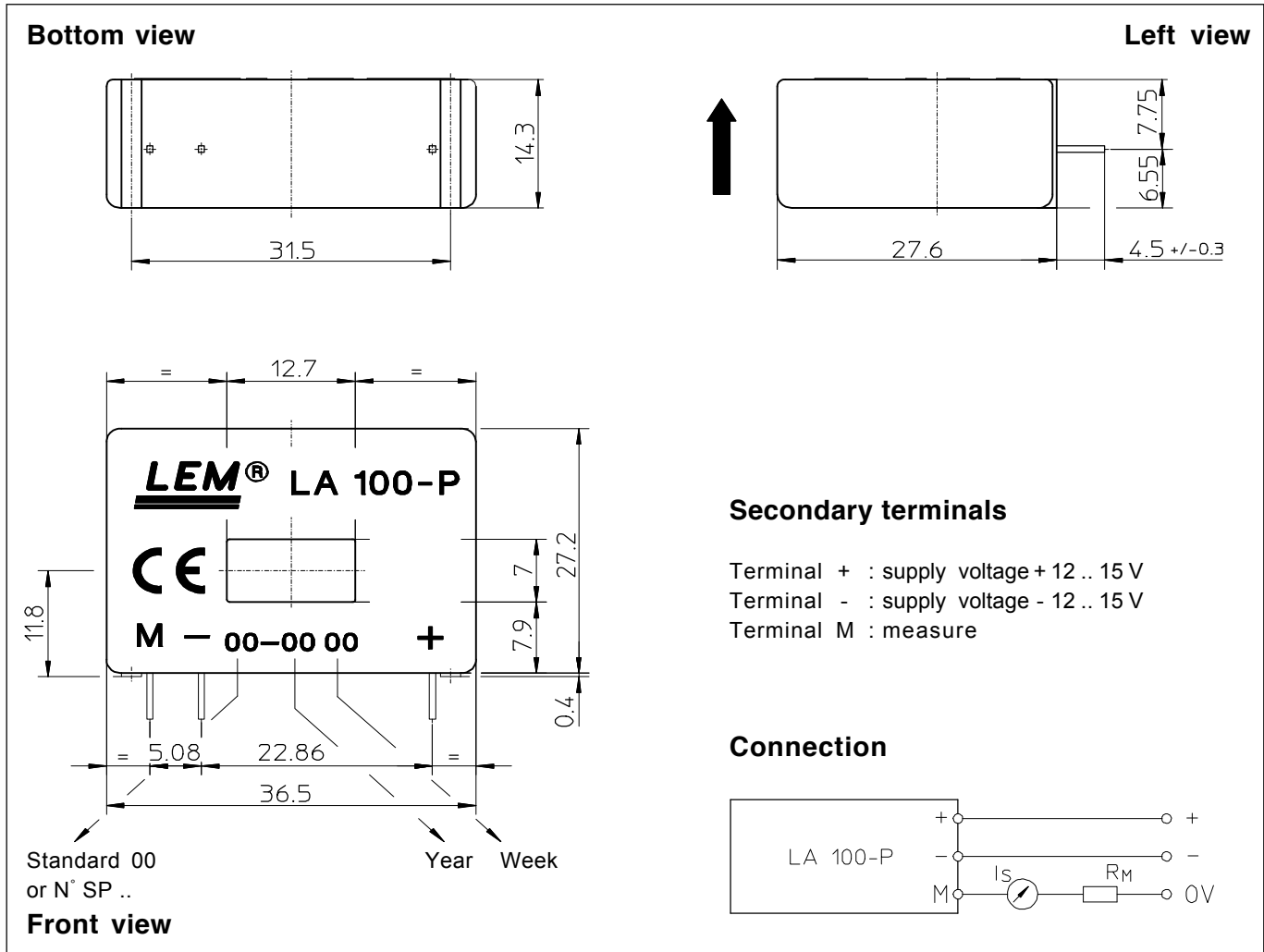
Dimensions LA 100-P (in mm. 1 mm = 0.0394 inch)

Mechanical characteristics

- General tolerance ± 0.2 mm
- Primary through-hole 12.7 x 7 mm
- Fastening & connection of secondary 3 pins
- Recommended PCB hole 0.63 x 0.56 mm
- Recommended PCB hole 0.9 mm

Remarks

- I_s is positive when I_p flows in the direction of the arrow.
- Temperature of the primary conductor should not exceed 100°C.
- Dynamic performances (di/dt and response time) are best with a single bar completely filling the primary hole.
- In order to achieve the best magnetic coupling, the primary windings have to be wound over the top edge of the device.
- This is a standard model. For different versions (supply voltages, turns ratios, unidirectional measurements...), please contact us.