

Current Transducer LA 305-S

$$I_{PN} = 300 \text{ A}$$

For the electronic measurement of currents : DC, AC, pulsed..., with a galvanic isolation between the primary circuit (high power) and the secondary circuit (electronic circuit).



16173

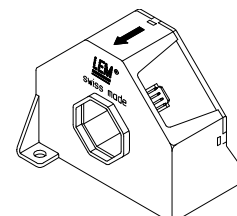

Electrical data

I_{PN}	Primary nominal r.m.s. current	300	A					
I_P	Primary current, measuring range	0 .. ± 500	A					
R_M	Measuring resistance @	$T_A = 70^\circ\text{C}$		$T_A = 85^\circ\text{C}$				
		$R_{M \min}$	$R_{M \max}$	$R_{M \min}$	$R_{M \max}$			
		with $\pm 12 \text{ V}$	@ $\pm 300 \text{ A}_{\max}$	0	52	0	50	Ω
			@ $\pm 500 \text{ A}_{\max}$	0	17	0	15	Ω
		with $\pm 15 \text{ V}$	@ $\pm 300 \text{ A}_{\max}$	0	75	5	73	Ω
			@ $\pm 500 \text{ A}_{\max}$	0	31	5	29	Ω
I_{SN}	Secondary nominal r.m.s. current	120	mA					
K_N	Conversion ratio	1 : 2500						
V_C	Supply voltage ($\pm 5 \%$)	$\pm 12 \dots 15$	V					
I_C	Current consumption	$20 (@ \pm 15 \text{ V}) + I_S$	mA					
V_b	R.m.s. rated voltage ¹⁾ , safe separation	1750	V					
		basic isolation	3500	V				

Features

- Closed loop (compensated) current transducer using the Hall effect
- Insulated plastic case recognized according to UL 94-V0
- Copyright protected.

Advantages

- Excellent accuracy
- Very good linearity
- Low temperature drift
- Optimized response time
- Wide frequency bandwidth
- No insertion losses
- High immunity to external interference
- Current overload capability.

Accuracy - Dynamic performance data

X_G	Overall accuracy @ I_{PN} , $T_A = 25^\circ\text{C}$	± 0.8	%
ϵ_L	Linearity	< 0.1	%
I_O	Offset current @ $I_P = 0$, $T_A = 25^\circ\text{C}$	Typ	Max
			± 0.20 mA
I_{OM}	Residual current ²⁾ @ $I_P = 0$, after an overload of $3 \times I_{PN}$		± 0.40 mA
I_{OT}	Thermal drift of I_O - $10^\circ\text{C} \dots + 85^\circ\text{C}$	± 0.12	± 0.30 mA
t_{ra}	Reaction time @ 10 % of I_{PN}	< 500	ns
t_r	Response time ³⁾ @ 90 % of I_{PN}	< 1	μs
di/dt	di/dt accurately followed	> 100	A/ μs
f	Frequency bandwidth (- 3 dB)	DC .. 100	kHz

General data

T_A	Ambient operating temperature	- 10 .. + 85	$^\circ\text{C}$
T_S	Ambient storage temperature	- 40 .. + 90	$^\circ\text{C}$
R_S	Secondary coil resistance @	$T_A = 70^\circ\text{C}$	35 Ω
		$T_A = 85^\circ\text{C}$	37 Ω
m	Mass Standards ⁴⁾	200	g
		EN 50178	

Applications

- AC variable speed drives and servo motor drives
- Static converters for DC motor drives
- Battery supplied applications
- Uninterruptible Power Supplies (UPS)
- Switched Mode Power Supplies (SMPS)
- Power supplies for welding applications.

Notes : ¹⁾ Pollution class 2. With a non insulated primary bar which fills the through-hole
²⁾ The result of the coercive field of the magnetic circuit
³⁾ With a di/dt of 100 A/ μs
⁴⁾ A list of corresponding tests is available.

Dimensions LA 305-S (in mm. 1 mm = 0.0394 inch)

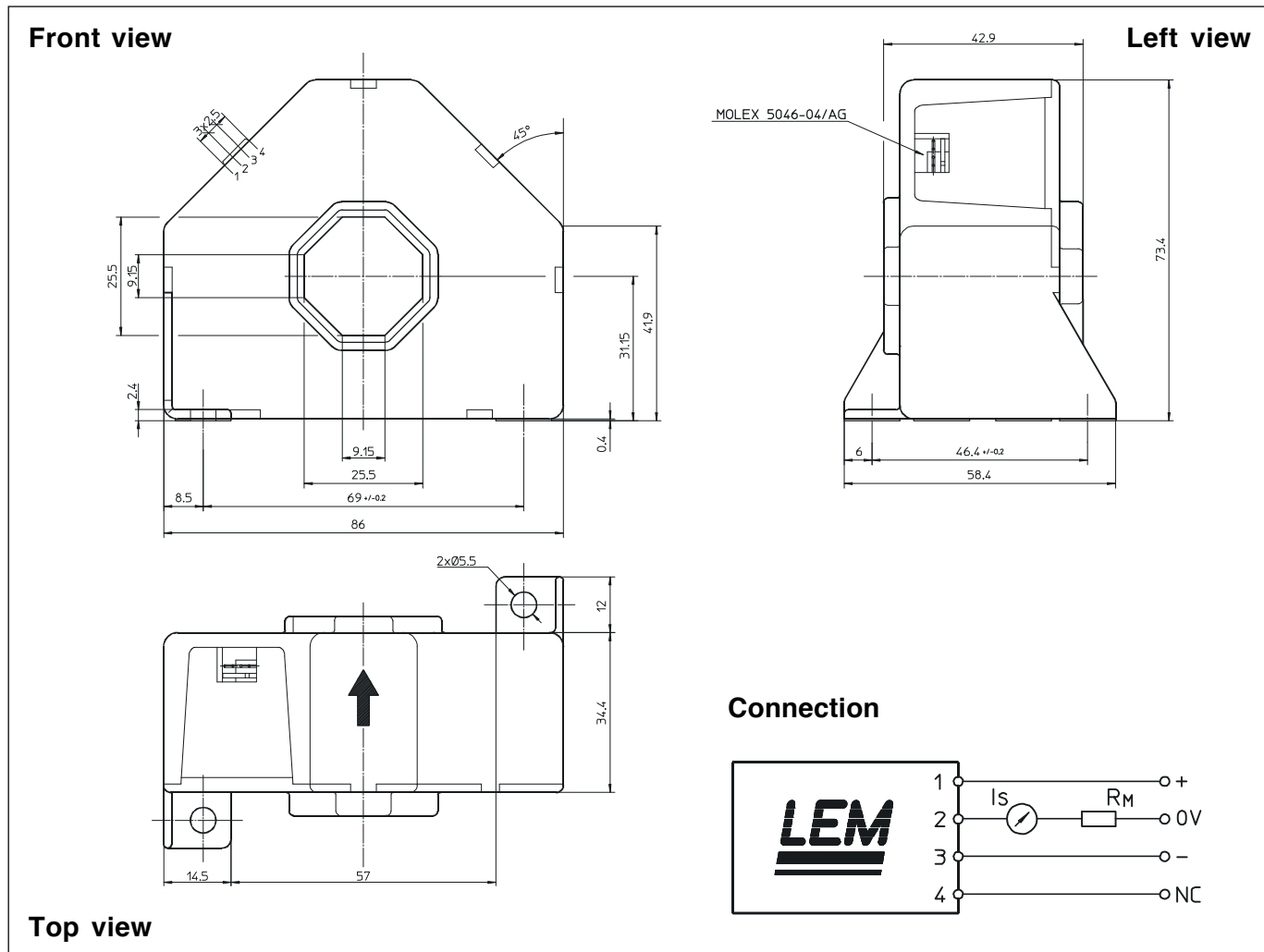

Mechanical characteristics

- General tolerance ± 0.5 mm
- Transducer fastening 2 holes $\varnothing 5.5$ mm
2 M5 steel screws
- Fastening torque, maxi 4 Nm or 2.95 Lb. - Ft
- Primary through-hole 25.5 x 25.5 mm
- Connection of secondary Molex 5046-04/AG

Remarks

- I_s is positive when I_p flows in the direction of the arrow.
- Temperature of the primary conductor should not exceed 100°C.
- Dynamic performances (di/dt and response time) are best with a single bar completely filling the primary hole.
- This is a standard model. For different versions (supply voltages, turns ratios, unidirectional measurements...), please contact us.