



PAC2 POWER CONTROLLER

PAC2
X10461

INTRODUCTION
The PAC2 module is a 6KW (25A) 230V ac phase angle, full wave controller in a compact easy to install package AC. It is capable of regulating up to. The PAC2 regulator governs the amount of power supplied to the load, by controlling the phase angle of the AC supply. The low thermal impedance and high electrical isolation provides the equipment designer with a greater flexibility in a wide variety of applications.

APPLICATIONS
Suitable for most power control applications such as infra/red quartz and ceramic heaters and lighting. It can also be used on inductive loads such as transformers and ac motors.

- FEATURES**
- Solid state reliability
 - Surface mount technology
 - 50 to 250V AC supply range
 - Rugged and compact
 - 25A current capability (with use of additional heatsink)
 - Internal snubber - eliminates 'nuisance switching'

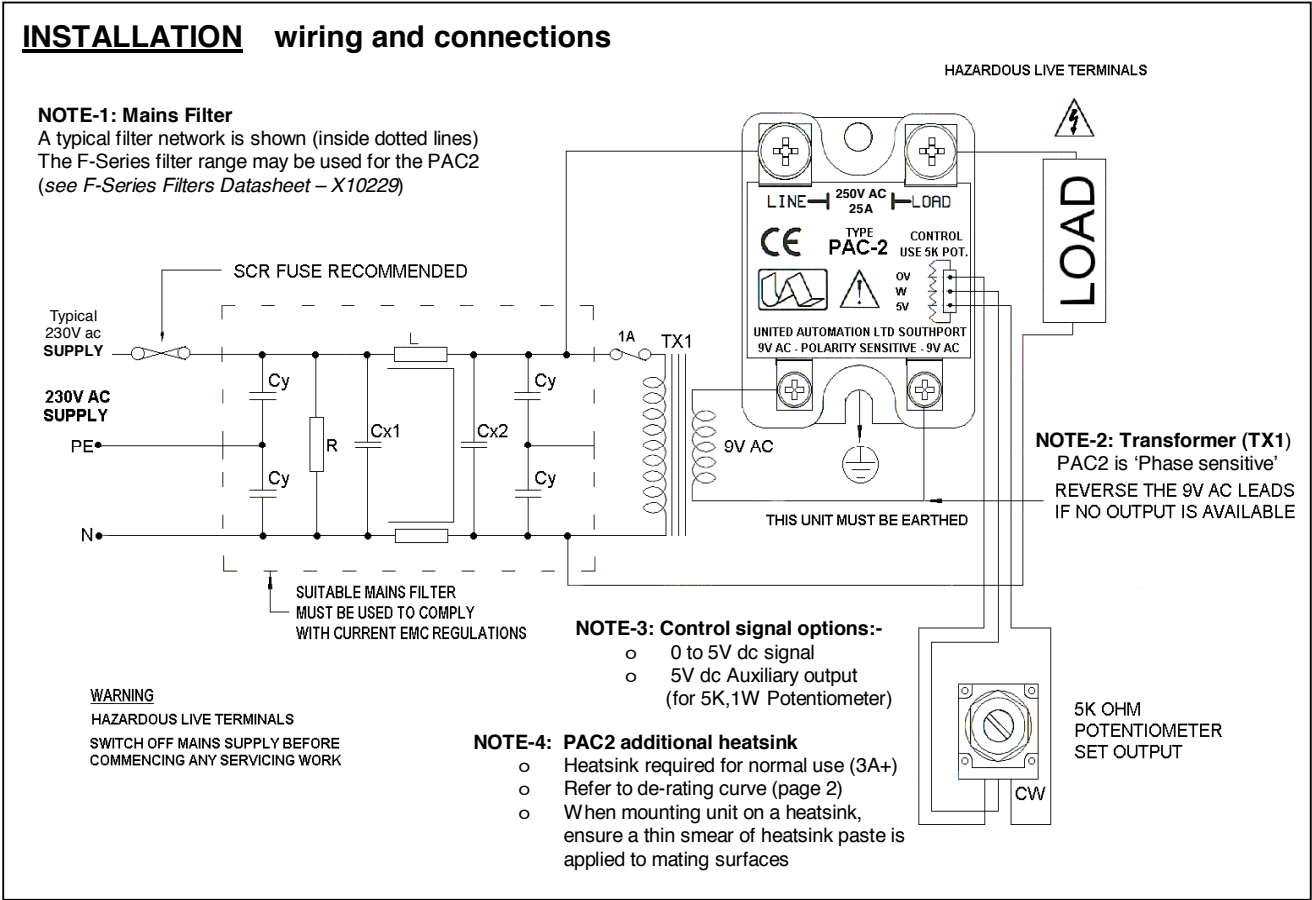
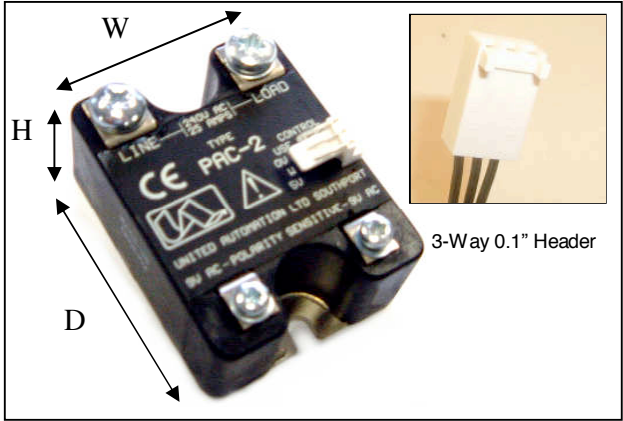

INSTALLATION

De-rating curve (to determine appropriate heatsink requirements)

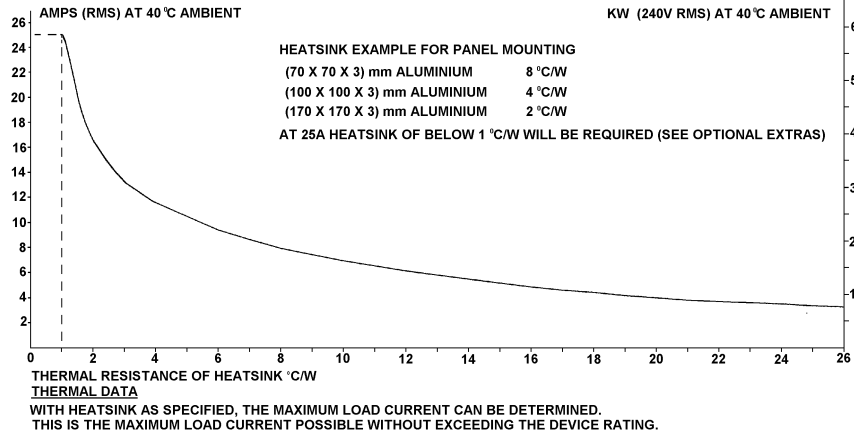

SPECIFICATIONS

AC line voltage range (Max./Min.)	50 to 250V @ 50/60 Hz	AC Aux input supply	10V ac (+/-2V) @ 50mA
Unit limiting RMS current	25A	I ² t for fusing	250 A ² s
Peak one cycle surge (10ms)	250A	Max peak voltage	600Vac
Minimum operating current	0.05A	Leakage current	5mA
Isolation voltage	3500Vrms	Control Signal (3-way 0.1" header)	0-5V or 5V Aux O/P (for Pot.)
		Power consumption	1.2 watts
Recommended Potentiometer	5K Ohm, 1W	Weight	63g
Storage temperature	0°C to +65°C	Maximum operating temperature	65°C
Dimensions:	57mm ((D) x 44mm (W) x 28mm (H)	Fixing centres:	48mm pitch with 2 @ 4.5mm Ø (M4 clearance) holes
Connections:	AC Aux input supply terminals		= 2-off M4 x 10mm pozi set screws (for use with spade or eyelet crimp connectors)
	AC line voltage terminals		= 2-off M5 x 10mm pozi set screws (for use with spade or eyelet crimp connectors)

FUSING

It is recommended that semiconductor, fast acting type fuses or circuit breakers (Semiconductor - MCB) be used for unit protection and an appropriate safety fuse for unit supply (F1A). On initial operation some loads may need an increased factor of safety (F of S) for unit and/or device protection. See SRA Data/sheet for further information.

CE MARKING

This product family carries a "CE" marking. These phase angle controllers need a suitable remote filter. For information see recommendation section and contact our sales desk. See Declaration of Conformity.

RECOMMENDATIONS

Other documents, which may be appropriate for your application, are available on request:

CODE	IDENTITY	DESCRIPTION
X10229	RFI	Filter recommendations: Addressing the EMC Directive
X10213	ITA	Interaction: Uses for phase angle and for burst fire control.
X10255	SRA (LVD)	Safety requirements: Addressing the Low Voltage Directive including, Thermal data/cooling, Live parts warning, Earth requirements and fusing recommendations.
AP02/4	COS	UAL Conditions of sale.

NOTE: It is recommended that installation and maintenance of this equipment should be carried out by suitably qualified/trained personnel with reference to the current edition of the I.E.E. wiring regulations (BS7671). The regulations contain important requirements regarding the safety of electrical equipment. For International Standards refer to I.E.C. directive IEC 950.

ORDER CODE

State part number: **PAC2**

(Supplied with 3-way control signal connector [0.1" header each end] & lead [0.5m long] – Part ref.: J50109)

Optional extras includes: Potentiometer, Filter, Transformer, Heatsink paste, and Heatsink assembly



UNITED AUTOMATION LIMITED

1 Southport Business Park
Kew
Southport, PR8 4HQ
ENGLAND

Page No. 2 of 2 Issue 3

Tel: 0044 (0) 1704 – 516500 Main
Tel: 0044 (0) 1704 – 516516 Sales
Fax: 0044 (0) 1704 – 516501
Enquiry@united-automation.com
www.united-automation.com
Date 23/05/08

